

GHD HARTMANN international
Represented in more than 35 countries – see www.ghd.net



PACKAGING

SW 40 L – SEALING UNIT

Technical Data

Dimensions:	Length:	approx. 2350 mm
	Width:	approx. 1700 mm
	Height:	approx. 2250 mm
Product dimensions:	Length:	250 - 600 mm
	Width:	200 - 400 mm
	Height:	60 - 170 mm
Capacity:	20 packages / min (depending on the product)	
Controller:	Siemens	
Frequency converter:	SEW	
Pneumatic system:	Festo	
Power supply:	400 Volt / 50 Hz	
Power input:	4 kW	
Compressed air:	min. 6.0 bar (ISO 8573-1)	
Weight:	approx. 1100 kg	

23 A



› SW 40

**GHD Georg Hartmann
Maschinenbau GmbH**
Schwalbenweg 24
D-33129 Delbrück, Germany
Tel: +49 (0)5250.9843-0
Fax: +49 (0)5250.9843-33
Web: www.ghd.net
E-mail: info@ghd.net





SW 40 L – sealing unit

The HARTMANN SW 40 L-sealing unit is ideal for full film wrapping of individual or grouped products. Variable pack sizes meet specific market requirements and product-related conditions. The packs are created from a continuous film, which is folded and fed crosswise in two layers from a roll. Inside the machine, the products run in between the separated top and bottom film. A device could evacuate the package before final sealing. The film is sealed in transverse and longitudinal direction. The split-separated film overhang is collected on the roller provided for this purpose. Good accessibility is provided by large door-openings and sliding or swivelling components. Adjustment devices are directly accessible and enable optimal handling.

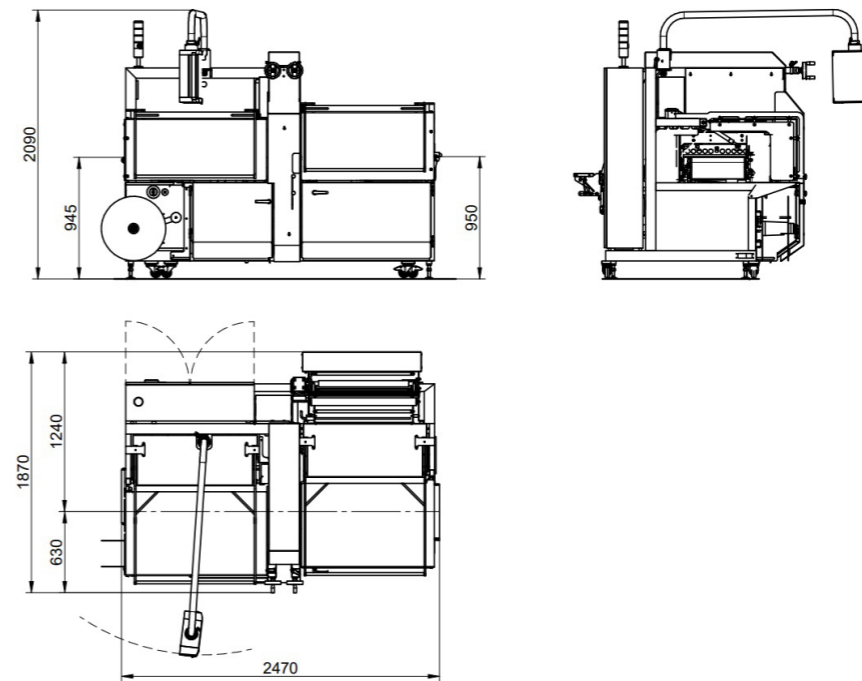

Non-binding suggested set-up drawing.

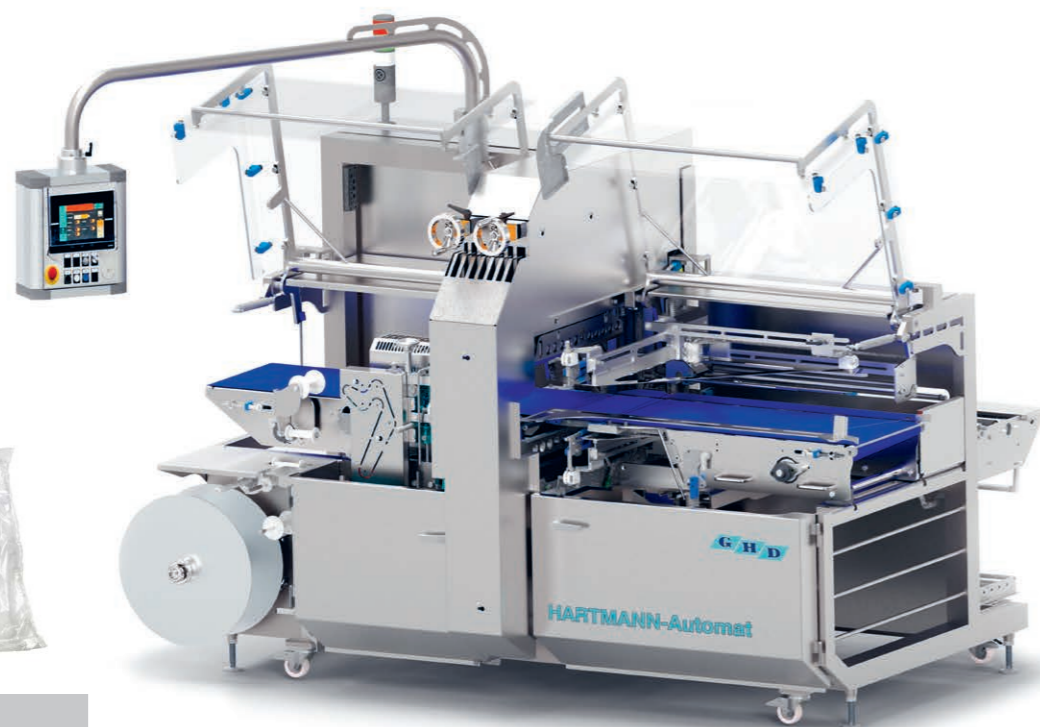

Overview of the SW 40 L-sealing unit

- › Machine frame made of welded stainless steel, standard
- › Drive conveyor system with adjustable speed
- › Infeed belt can be pulled out to the side for manual film infeed
- › Film magazine for one roll with manually adjustable unwind position
- › Manual set-up mode for film insertion
- › Longitudinal and transverse sealing unit, permanent heated and non-stick coated
- › Adjustment unit for transverse sealing bar, manual positioning in height and width
- › Cross-sealing unit can be pulled out to the side
- › Longitudinal foldable - simplified access for maintenance
- › Evacuating of the pack via lance according to the injector principle
- › Winding reel for cut-off film overhang, driven
- › Control panel, with swivelling holder
- › Control + touch screen Siemens



Food Grade

All product contact materials are stainless steel or food-contact-approved plastics.



Central adjustment point

All settings for product change by two handwheels.



Easy accessibility

For service and maintenance.



Close packaging

Evacuation with injector principle.

