



SLICING

GS 60 RECIPROCATING SLICER

Technical Data

Dimensions:	Length:	2,890 mm
	Width:	1,100 mm
	Height:	1,620 mm
Product dimensions:	Length:	160-400 mm
	Height:	50-170 mm
Slice thickness:	min. 7 mm	
Capacity:	up to 3,600 product units/h (depending on the product)	
Blade length:	358 mm	
Blade stroke:	77 mm	
Controller:	Omron	
Frequency controller:	Hitachi	
Power supply:	230/400 Volt / 50 Hz	
Power input:	3.5 kW	
Compressed air:	min. 6.0 bar (ISO 8573-1)	
Weight:	1,100 kg	

25 A



- › GS 60
- › GS 60 XL
- › GS 60 XXL

**GHD Georg Hartmann
 Maschinenbau GmbH**
 Schwalbenweg 24
 D-33129 Delbrück, Germany
 Tel: +49 (0) 5250.9843-0
 Fax: +49 (0) 5250.9843-33
 Web: www.ghd.net
 E-mail: info@ghd.net



GS 60

Reciprocating Slicer



The GS 60 reciprocating slicer is a high-performance cutting machine for bread, fruit breads, raisin yeast loaves or similar products which contain sugar. The vertical positioning of the blades allow to cut the product with equal precise slice thicknesses. The GS 60 is designed for continuous operation. The high output is based on an in-house designed HARTMANN gearbox, which is equipped with a special oil lubrication system. A separate frequency-controlled drive fit at the outfeed conveyor allows an optimized synchronization with the automatic bagging machine. The combination of this reciprocating slicer together with a HARTMANN automatic bagging machines by will provide a perfect harmonized package solution with high flexibility and production reliability.

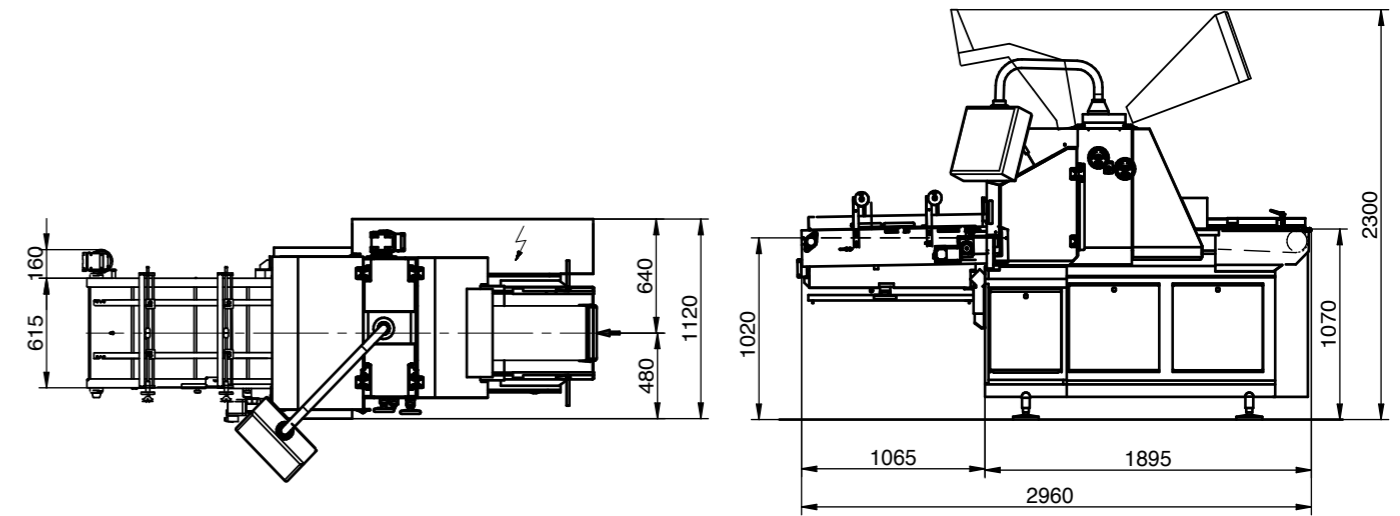

Non-binding suggested set-up drawing.



Overview of GS 60 reciprocating slicer features

- > Slices bread, fruit breads, raisin yeast loaves and products which contain sugar, grain and nuts
- > Precise vertical blade arrangement
- > 4 conveyor elements of the product infeed fixate the product on all sides
- > Product infeed is adjusted to the shape and characteristics of your products
- > Equipment stops if blade breaks
- > Stepless adjustable speed for product infeed, product outfeed, and blade
- > Fast cleaning by sliding the product infeed out of the cutting area by 250 mm
- > Blade frame can be pulled out from the top after removing just a single nut
- > Special HARTMANN-gearbox for the smooth blade drive

Display

Intuitive operation via touch screen.



Blade frame

The infeed and slicing speeds can be adjusted.



Optional:

- > Separating guides for half loafs
- > Adjustable transfer panels
- > End slice separator
- > Guide panels with anti-stick coating
- > Product outfeed designed as conveyor belt (optimum for manual unloading)
- > Slice thickness from 6 mm upwards
- > Product-specific blade strokes between 20- 100 mm
- > GS 60 XL: Working width up to 550 mm
- > GS 60 XXL: Working width up to 750 mm