



CLOSING

EC 101 H CLOSING UNIT



Technical Data

Dimensions:	Length:	approx. 3,660 mm
	Width:	approx. 1,500 mm
	Height:	approx. 1,800 mm
	Working height:	approx. 950 mm
Product dimensions:	Length:	max. 400 mm
	Width:	max. 220 mm
	Height:	max. 120 mm
	(other dimensions upon request)	
Capacity:	up to 60 packages / min (depending on product)	
Controller:	Omron	
Frequency controller:	Hitachi	
Power supply:	230/400 Volt / 50 Hz	
Power input:	2 kW	
Compressed air:	min. 6.0 bar (ISO 8573-1)	
Weight:	700 kg	

Available additional equipment:

- › Hot foil printer ,HPD' for labelling plastic clip tape
- › Unit equipped with tape closing system or sealing closing system
- › Applicator for labels

25 A

**GHD Georg Hartmann
 Maschinenbau GmbH**
 Schwalbenweg 24
 D-33129 Delbrück, Germany
 Tel: +49 (0)5250.9843-0
 Fax: +49 (0)5250.9843-33
 Web: www.ghd.net
 E-mail: info@ghd.net



- › EC 101 H
- › EC 101 HS
- › EC 101 IS
- › EC 101 KS
- › EC 104
- › EC 108 SV
- › EC 110
- › EC 130
- › EC 135
- › EC 140
- › EC 140 S
- › EC 150 V
- › EC 155



EC 101 H

Closing Unit



This packaging machine consists of two bag inflating tables and a horizontal closing device arranged at right angles. Wheels and the compact design make this sealer flexible and usable at any location. By simply opening the machine doors, all drive elements are directly accessible. The bags are opened with the bag inflating tables. Different products such as whole loaves or sliced loaves can be easily inserted by hand and placed on the transversely positioned product carrier belt. The filled bags are automatically transported to the sealing station and aligned to ensure an optimum packaging result. An integrated vacuum device sucks excess air out of the bag before it is sealed.

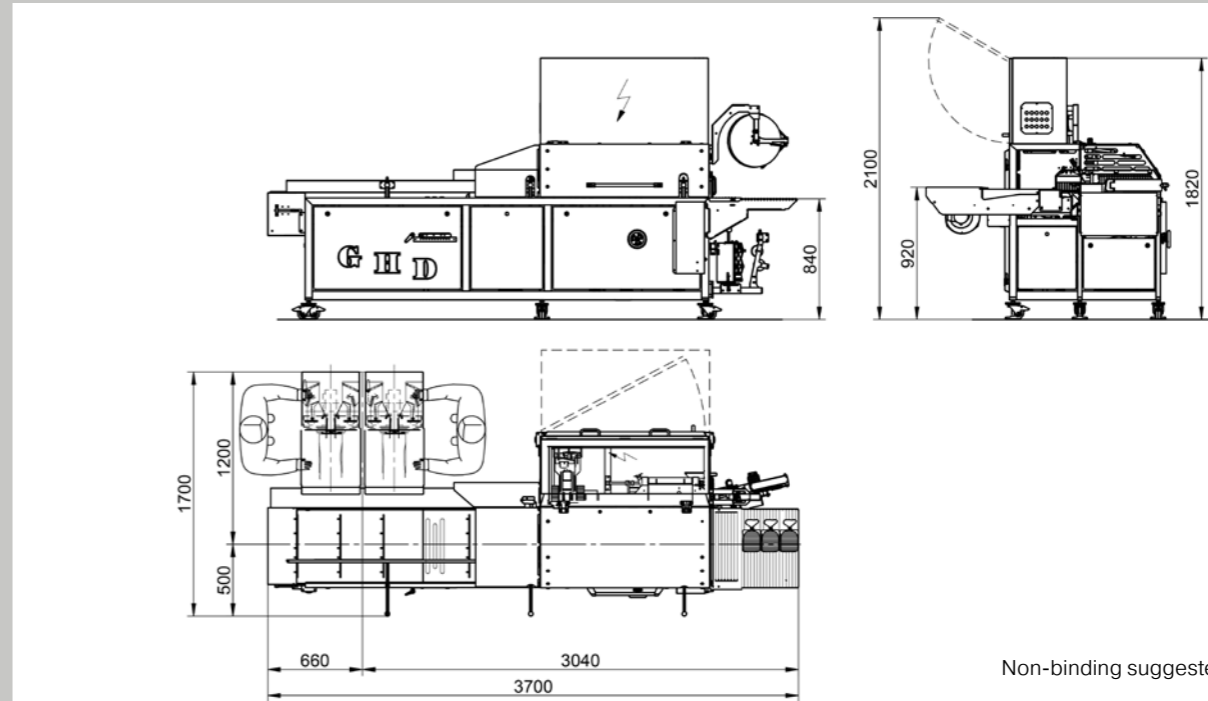

Non-binding suggested set-up drawing.



◀ **EC 101 H + GS 60**
Best practice with any combination of the EC 101 H and a Selectra slicing machine or with a reciprocating slicer GS 60.

Closure material roll with feed
 > Easily accessible magazine roll for closing material.
 > Optional extension with an HPD printer.



„Rotating clap” for smoothing the product bags and vacuum clipping station
 The clap aligns the bags before closing. The vacuum device sucks excess air out of the bag.



Twin bag opening tables
 Bag opening table for opening the bags by blowing air into them. Whole loaves or sliced bread loaves can easily be inserted by hand.



Optional: tamper-evident closure
 > perforating and sealing the ruffle
 > one- or double-row version



Optional: Printing unit
 Hot foil printer 'HPD' for labelling plastic clip tape.

